

A
B
C
D
E
F
G

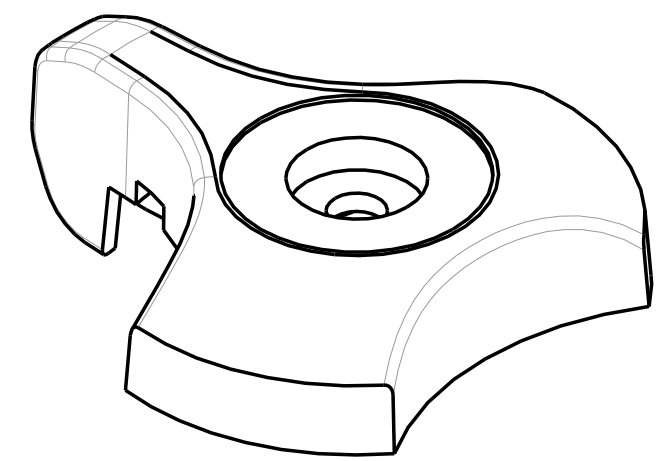
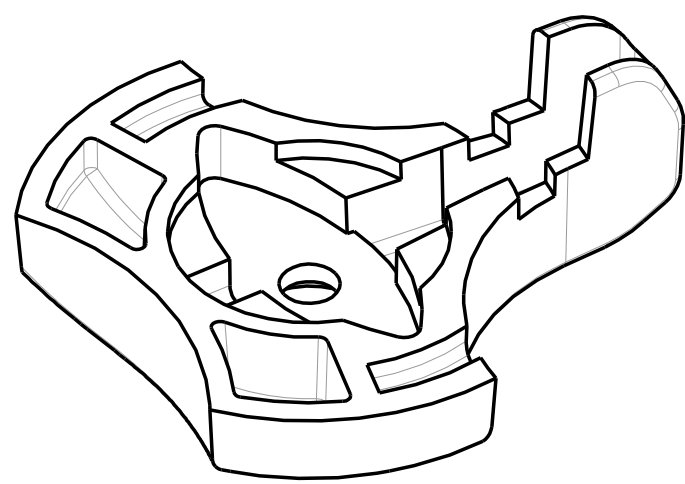
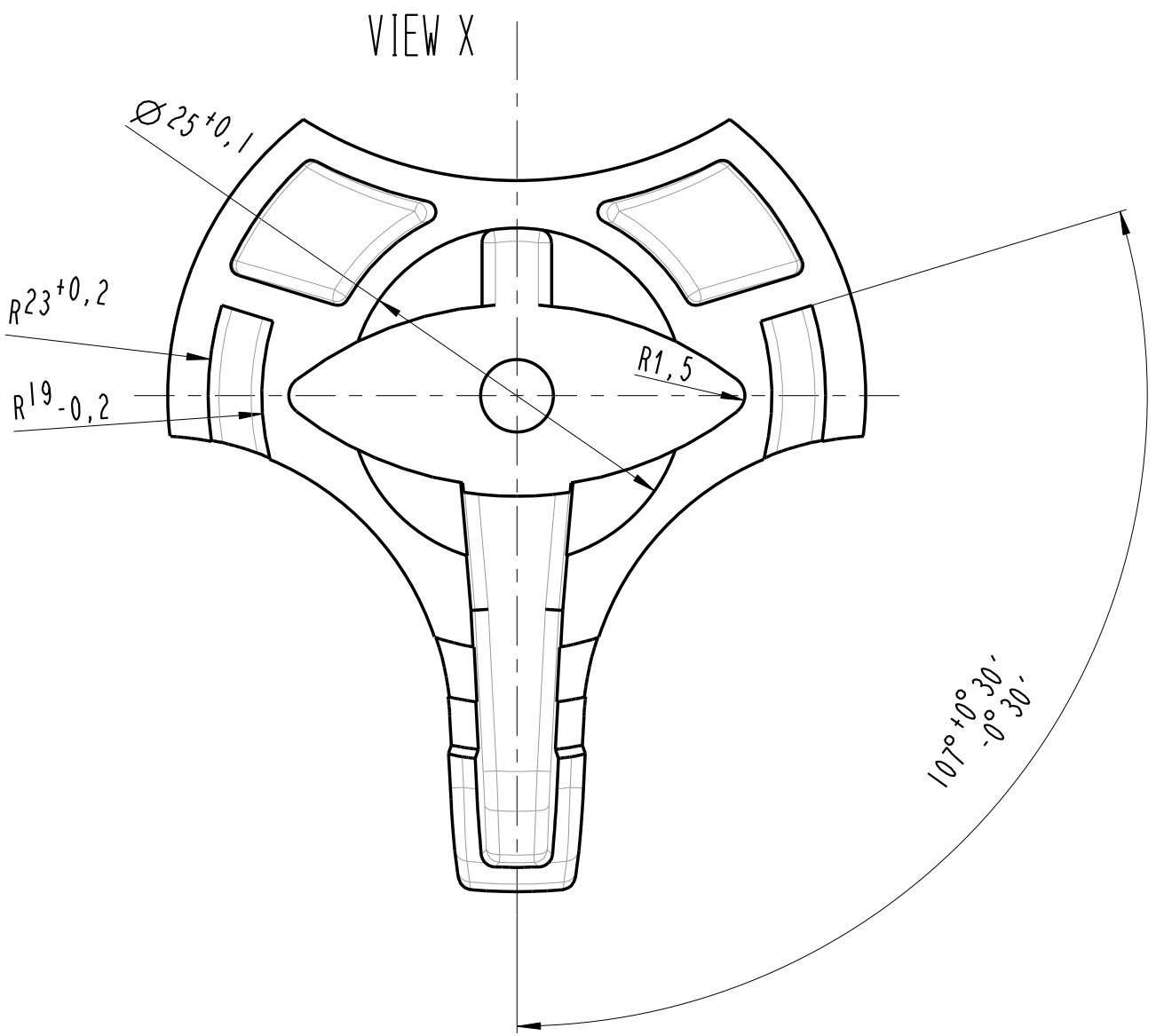
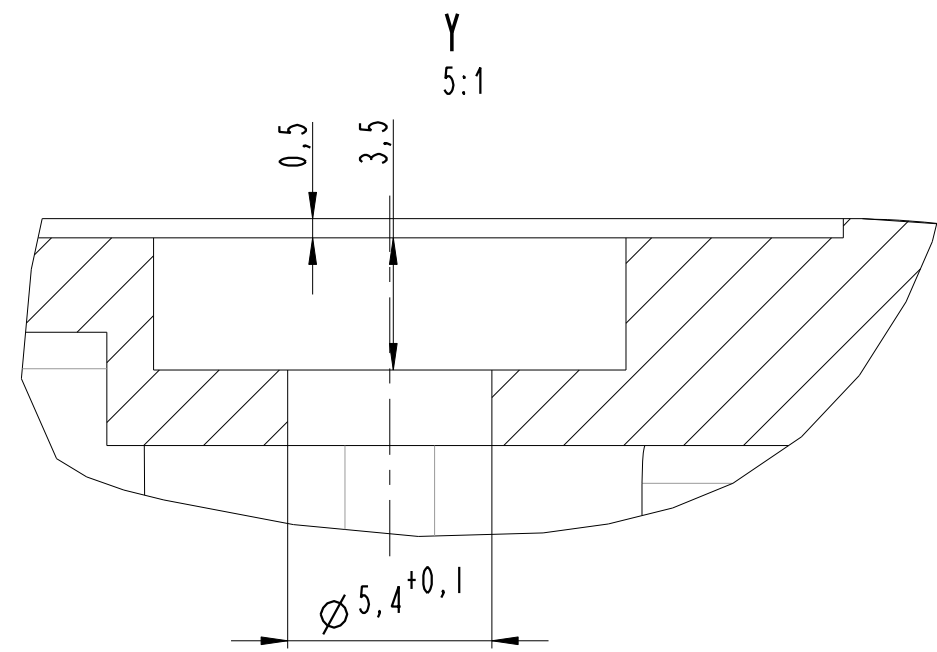
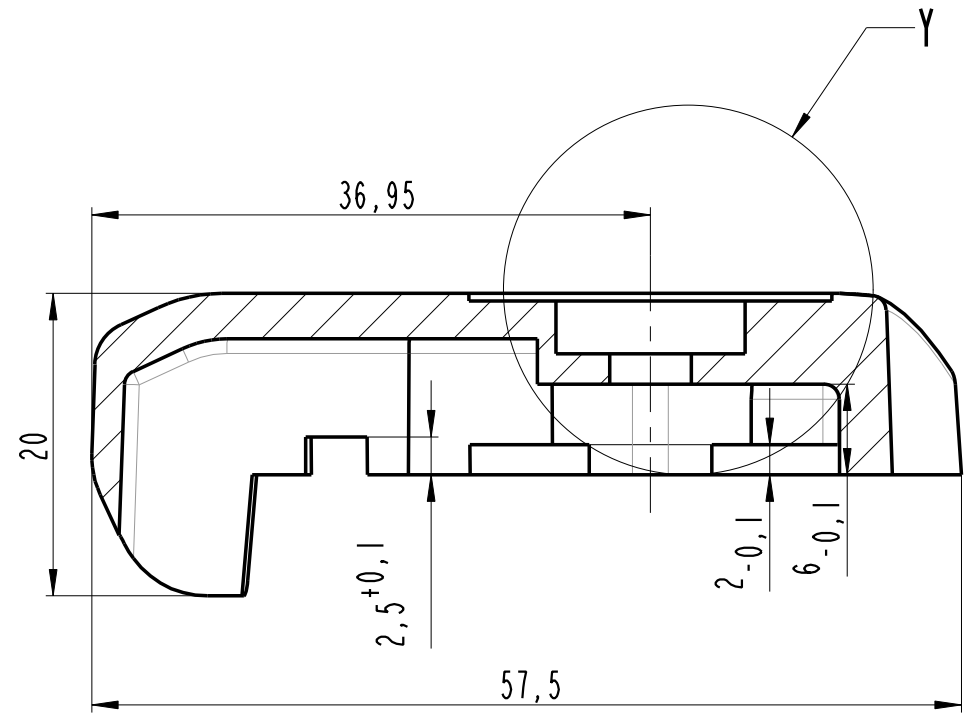
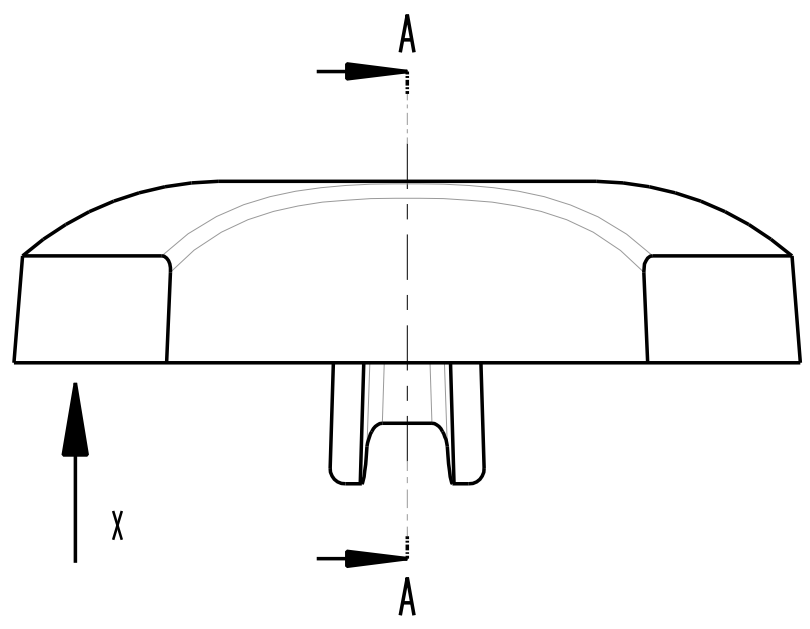

UVOLNENO PRO VYROBU FOREM 31.5.2016

			PA6		14,712		000
Pocet kusu / Quantity	Název - rozmer / Title - size	Polotovár / Blank	Material konečný/výchozí / End material/Material	T.odp.	C.hmot. / Weight	Hr.hmot. / Raw weight	C. výkr. sestavy / Drawing asm. No.
	Datum / Date	Jmeno/Name	Datum / Date	Name			
Kreslil / DWN.	2016-05-31	Cerven	Techno-log/ist				
Prezk. /CHK			Prezk. /CHK		2	odebrani materialu zevnitř	9.4.2010
Schval. /APP			Schval. /APP		1	zmena z $\varnothing 60.8\text{ mm}$	24.7.06
	index/No.	Schválil/Aprpr.		popis zmeny/change		Datum	Podpis/N
Poznámka/Note:							

Methode 1 ISO 128	TOLERANCE / TOLEROVANI ISO 80015 ISO 2768mK	Soubor-model /PART-file Soubor-vykres/DRW-file	LID_NEW	Meritko SCALE	2:1	C.sestavy / Assembly No.	
Název / Title			LID_NEW		CISLO VYKRESU /DRAWING NO.		For SI.
					015 - B		
			List/sheet 1		pocet listu/ no.sheets 1		

1 2 3 4 5 6 7 8 9